

N 70, Built-in freezer, 87.4 x 55.8 cm
G11216DE0



COOKING PASSION SINCE 1877



This built-in freezer helps to defrost faster and features a malfunction warning signal in case of increasing temperature.

- ✓ LowFrost: Reduces frost in the freezer compartment for faster defrosting.
- ✓ BigBox: An abundance of storage space even for large and bulky items.
- ✓ Softclose: When it reaches an angle of 20° the door softly closes itself.

Features

Technical Data

Energy Efficiency Class (Regulation (EU) 2017/1369) : E
Average annual energy consumption in kilowatt hour per year (kWh/a) (EU) 2017/1369 : 176
Sum of volume of frozen compartments (EU 2017/1369) : 96
Airborne acoustical noise emissions (EU 2017/1369) : 36
Airborne acoustical noise emission class (EU 2017/1369) : C
Thermometer freeze section : None
Light : No
Product category : Upright freezer
Construction type : Built-in
Door panel options : Not possible
Frost free system : No
Height of the product (mm) : 874
Width of the appliance : 558
Depth of the product : 545
Dimensions of the packed product (HxWxD) (mm) : 950 x 640 x 620
Net weight (kg) : 39.838
Gross weight (kg) : 42.6
Connection rating (W) : 90
Current (A) : 10
Frequency (Hz) : 50-60
Approval certificates : CE, VDE
Length of electrical supply cord (cm) : 230
Door hinge : Right reversible
Storage Period in Event of Power Failure (h) : 13
Defrost process : manual
Warning signal / malfunction : visual and audible
Lockable door : No
Number of drawers/baskets (Stck) : 3
Number of freezing flaps (Stck) : 0
EAN code : 4242004247623
Brand : Neff
Product name / Commercial code : G11216DE0
Product category : Upright freezer



4 242004 247623

Features

Design features

Functions

- Fixed hinge
- lowFrost freezer - less ice build up, faster defrosting
- SuperFreeze function with automatic deactivation
- Electronic control (LED chain)
- Freezer malfunction warning signal: optical, acoustical

Food freshness system

- 3 transparent freezer drawers, 1 bigbox

Key features - Fridge section

- Right hinged door, reversible
- Connection value 90 W
- 220 - 240 V

Dimension and installation

- Dimensions: 87.4 cm H x 55.8 cm W x 54.5 cm D
- Niche Dimensions: 88 cm H x 56 cm W x 55 cm D

Key features - Freezer section

- ice cube tray

Included accessories

- KF1213S0, KF1213Z0

Design features

Dimension and installation

Country Specific Options

- Based on the results of the standard 24-hour test. Actual consumption depends on usage/position of the appliance.

Additional features

Performance and Consumption

- EU19_EEK_D: E
- Total Volume : 96 l
- Freezing capacity 24h : 5 kg
- Annual Energy Consumption: 176 kWh/a
- Climate Class: SN-T
- Noise Level : 36 dB

Dimensioned drawings

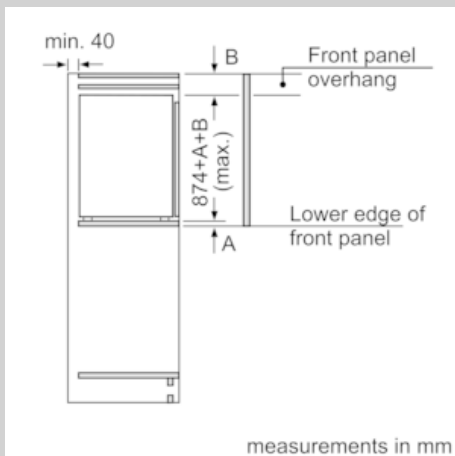
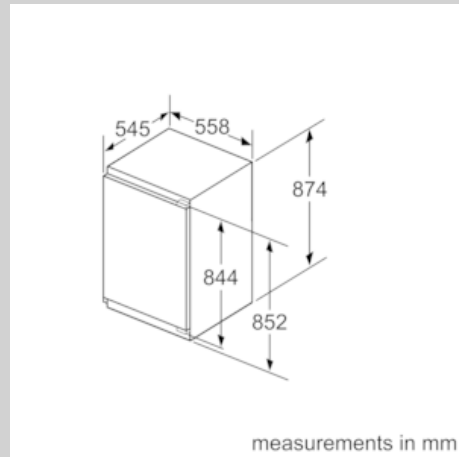
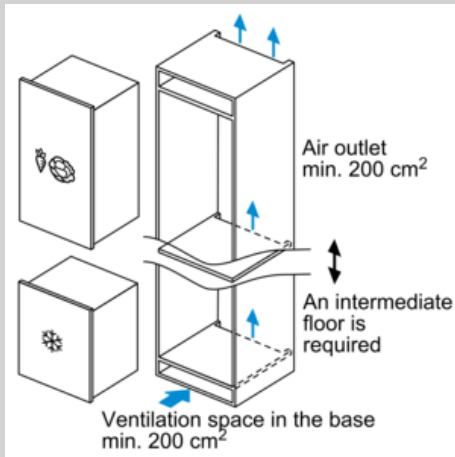

measurements in mm
Recommended gap dimensions for flat hinges

F	R	X
16-19	0-3	2.5
20	0-1	3
	2-3	2.5
21	0-1	3
	2-3	2.5
22	0	4
	1	3.5
	2-3	3

The gap dimensions recommended in the table must be adhered to in order to ensure that appliance doors do not collide with anything when they are opened, and to avoid causing damage to kitchen units.

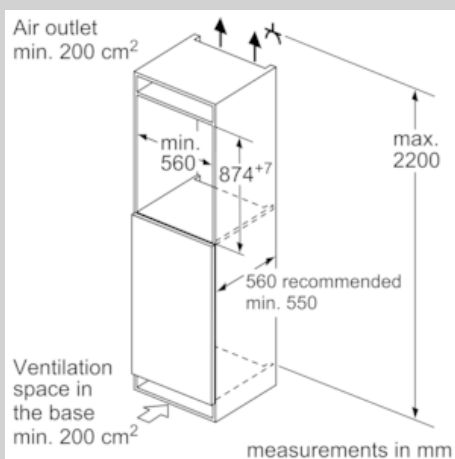

Maximal permissible weight of the unit fronts

Fitted unit fronts that exceed the permissible weight may cause damage and result in functional impairment of the hinges

Δ Weight
A: Appliance door height including hinges in mm
B: Undamped hinge, unit front in kg
C: Damped hinge, unit front in kg

A	B	C
1500-1750	22	22
720-1400	19	19
A1	15	19
A2	15	19