

**Serie | 4, Fully-integrated dishwasher,
60 cm
SMV4HAX40G**



Optional accessories

- SGZ1010 : inlet and outlet hose extention
- SMZ5003 : Retractable hinge f. high corpus dimens.
- SMZ5005 : Compensating + fixing kit, stainl. steel
- SMZ5035 : Decor conversion kit, stainless steel
- SMZ5300 : GlassSecure Tray

Easy loading of dishes and management of your dishwasher via the Home Connect app.

- **Home Connect:** home appliances with smart connectivity for an easier everyday life.
- **ExtraDry:** extra drying option for difficult-to-dry loads.
- **Silence on demand:** up to 30 min noise reduction at any time via the Home Connect App.
- **InfoLight:** a red infolight on the floor indicates whether the dishwasher is switched on or off.
- **Silence Programme:** the quietest way to run your dishwasher.

Technical Data

Energy Efficiency Class:	D
Energy Consumption for 100 cycles Eco Programme:	84
Maximum number of place settings:	13
The water consumption of the eco programme in liters per cycle:	9.5
Programme duration:	4:55
Airborne acoustical noise emissions :	46
Airborne acoustical noise emission class:	C
Construction type:	Built-in
Height of removable worktop (mm):	0
Dimensions of the product (HxWxD):	815 x 598 x 550
Required niche size for installation (HxWxD):	815-875 x 600 x 550
Approval certificates:	CE, VDE
Depth with open door 90 degree (mm):	1150
Adjustable feet:	Yes - all from front
Maximum adjustability feet (mm):	60
Adjustable plinth:	both horizontal and vertical
Net weight (kg):	33.812
Gross weight (kg):	36.0
Connection rating (W):	2400
Fuse protection (A):	10
Voltage (V):	220-240
Frequency (Hz):	50; 60
Length of electrical supply cord (cm):	175
Plug type:	GB plug
Length inlet hose (cm):	165
Length outlet hose (cm):	190
EAN code:	4242005265220
Installation type:	Full-integrated



Serie | 4, Fully-integrated dishwasher, 60 cm SMV4HAX40G

Easy loading of dishes and management of your dishwasher via the Home Connect app.

New for 2021

Performance

- Energy Efficiency Class¹: D
- Energy² / Water³: 84 kWh / 9.5 litres
- Capacity: 13 place settings
- Programme duration⁴: 4:55 (h:min)
- Noise level: 46 dB(A) re 1 pW
- Noise Efficiency Class: C
- Noise level (silence programme): 43 dB(A) re 1 pW

Programmes / functions

- 6 programmes: Eco 50 °C, Auto 45-65 °C, Intensive 70 °C, Express 65°, Silence 50 °C, Favourite
- Default favourite programme: Pre-Rinse
- 4 special options: Remote Start, Extra Dry, Half Load, SpeedPerfect+
- Machine Care
- Silence on Demand (via app)

Flexible design elements

- Flex basket system
- 3 stage Rackmatic height-adjustable top basket
- Low friction wheels on bottom basket
- Rack Stopper to prevent derailing of bottom basket
- 2 foldable plate racks in top basket
- 2 foldable plate racks in bottom basket
- Knife rack in top basket
- Moveable cutlery basket in lower rack
- Upper rack cup shelf

Innovations and technology

- Home Connect ready on WLAN
- Heat exchanger.
- DosageAssist detergent dispenser
- EcoSilence BLDC drive
- Automatic detergent detection
- AquaMix - Glass protection system
- Aqua and loading sensor

Design features

- Push button top edge controls
 - InfoLight (Red) - Light projection on the floor
 - Acoustic end of cycle indicator, Time remaining indicator (min), water inlet indicator
 - Time delay (3, 6 or 24 hours)
 - AquaStop: Bosch warranty in case of water damage - for the lifetime of the appliance. Please find warranty terms under <https://www.bosch-home.co.uk/customer-service/care-protection-and-parts/additional-warranties>
 - Self-cleaning filter system with 3 piece corrugated filter
 - Large item spray head, steam protection plate
 - Stainless steel interior
 - Dimensions (HxWxD): 81.5 x 59.8 x 55cm
- ¹ Scale of Energy Efficiency Classes from A to G
² Energy consumption in kWh per 100 cycles (in programme Eco 50 °C)
³ Water consumption in litres per cycle (in programme Eco 50 °C)
⁴ Duration of programme Eco 50 °C

Serie | 4, Fully-integrated dishwasher, 60 cm SMV4HAX40G

measurements in mm

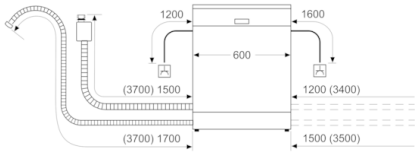

△ socket
○ values with extension kit

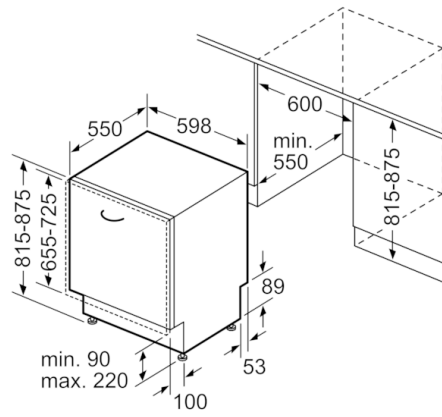

measurements in mm