

## iQ500, Built-in washing machine, 8 kg, 1400 rpm WI14W301GB



iSensoric fully integrated built-in washing machine with iQdrive and very high energy efficiency.

- ✓ iQdrive motor: Intelligent, quiet, and durable with warranty
- ✓ waveDrum for highly effective and extremely gentle laundry care.
- ✓ Lifetime protection against water damage -#quaStop®
- ✓ LED touch display shows all relevant information clearly and is easy to use

### Features

#### Technical Data

Energy Efficiency Class: C  
 Weighted energy consumption in kWh per 100 washing cycles of eco 40-60 programme: 62  
 Maximum capacity in kg: 8.0  
 The water consumption of the eco programme in liters per cycle: 45  
 Duration of eco 40-60 programme in hours and mins at rated capacity: 3:16  
 Spin-drying efficiency class of eco 40-60 programme: B  
 Airborne acoustical noise emission class: A  
 Airborne acoustical noise emissions : 66  
 Construction type: Built-in  
 Height of removable worktop (mm): 820  
 Dimensions of the product (mm): 818 x 596 x 544  
 Net weight (kg): 71.874  
 Connection rating (W): 2300  
 Fuse protection (A): 10  
 Voltage (V): 220-240  
 Frequency (Hz): 50  
 Approval certificates: CE, E17D UKCA marking, VDE  
 Length of electrical supply cord (cm): 210  
 Door hinge: Left  
 Wheels: No  
 EAN code: 4242003865811  
 Installation type: Full-integrated

### Optional accessories

WZ20441	Height-adjustable feet
WZ10131	Extension for cold water inlet /AquaStop
WX975600	Floor securing component



## iQ500, Built-in washing machine, 8 kg, 1400 rpm WI14W301GB

### Features

#### Performance

- Energy Efficiency Class<sup>1</sup>: C
- Energy<sup>2</sup> / Water<sup>3</sup>: 62 kWh / 45 litres
- Load capacity: 1 - 8 kg
- Programme duration<sup>4</sup>: 3:16 h:min
- Spin drying efficiency class: B
- Spin speed<sup>\*\*</sup>: 400 - 1400 rpm
- Noise level: 66 dB (A) re 1 pW
- Noise efficiency class: A

#### Programmes/functions

- Touch control buttons: Ready in, varioSpeed, start/pause with reload function, spin speed selection
- Special programmes: drain / spin, shirts/blouses, mixed fabrics, hygiene, rapid 15 minute quick wash, single rinse, handwash/wool, 30°C

#### Key features

- Reload Function: Stop the washing machine to add any forgotten items of laundry to the drum.
- waterPerfect Plus: for efficient use of water even with small loads thanks to intelligent sensor technology.
- antiVibration Design - for more stability and quietness
- EcoSilence drive with 10 year warranty

#### Additional features

- iQdrive with 10 year warranty
- Large display for programme progress indication, spin speed, remaining time, 24 hour end time delay and load recommendation.
- aquaStop: Siemens home appliance with lifetime warranty against water damage\*
- Foam detection system
- Out of balance load adjustment
- Detergent dispensing: easy clean
- Divider for Liquid Detergent
- End of cycle buzzer
- 

#### Technical Information

- Fully integrated
- Furniture door is reversible
- Dimensions (H X W X D): 81.8 x 59.6 x 57.4 cm
- Height adjustment with cardanDrive
- adjustable base height: 15 cm
- adjustable base depth: 6.5 cm

<sup>1</sup> Scale of Energy Efficiency Classes from A to G

<sup>2</sup> Energy consumption in kWh per 100 cycles (in programme Eco 40-60)

<sup>3</sup> Weighted water consumption in litres per cycle (in programme Eco 40-60)

<sup>4</sup> Duration of Eco 40-60 programme

\*\* Values are rounded.

\* Please find warranty terms under: <https://www.siemens-home.bsh-group.com/uk/customer-service/warranty/additional-warranties>

**iQ500, Built-in washing machine, 8 kg,  
1400 rpm  
WI14W301GB**

Dimensioned drawings

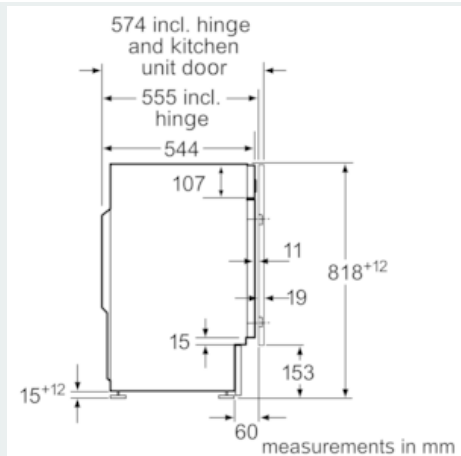
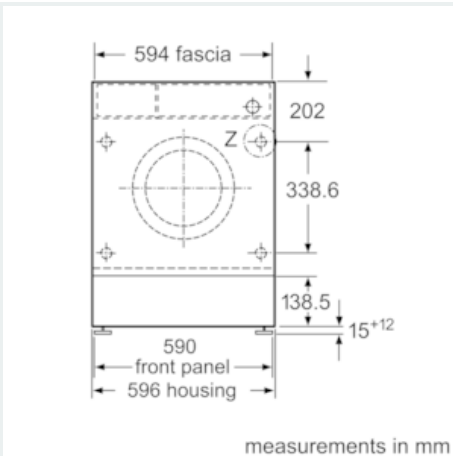

Z detail

